

3D VIEW

NOTE:  
 PRODUCTS MUST CONFORM TO JS SPEC JS-GC03143-A1.  
 1.MATERIAL:  
 HOUSING: LCP; UL94V-0; COLOR:BLACK  
 CAP: LCP; UL94V-0; COLOR:BLACK  
 CONTACT: C5191.  
 BOARDLOCK: BRASS  
 2.FINISH:  
 CONTACT: (SEE TABLE) GOLD PLATING ON CONTACT AREA.  
 100μ" MIN MATTE-TIN PLATING ON SOLDER TAIL,  
 1.27um [50μ"] MIN. NICKEL UNDERPLATING OVER ALL  
 BOARDLOCK: 100μ" MIN. MATTE-TIN OVER 50μ" MIN.  
 NICKEL PLATED.

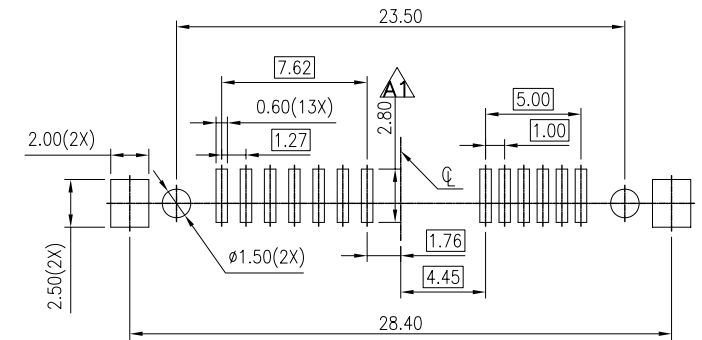

RECOMMEND P.C.B LAYOUT (TOP VIEW)  
 PCB ,ALL TOLERANCE:±0.05 MM

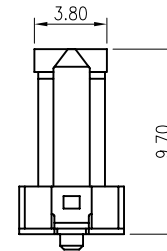
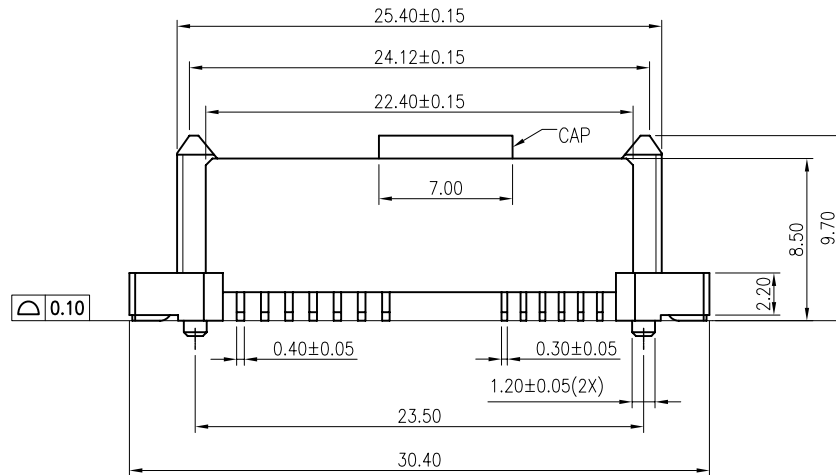
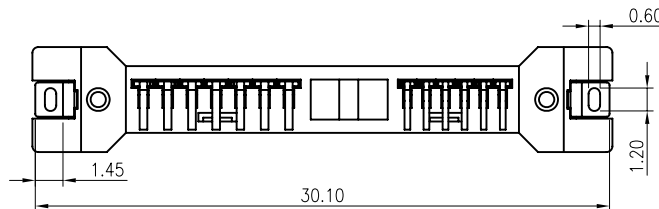

|              |      |         |             |        |      |      |              |              |            |       |        |
|--------------|------|---------|-------------|--------|------|------|--------------|--------------|------------|-------|--------|
|              |      |         |             |        |      |      |              |              |            |       |        |
|              |      |         |             |        |      |      |              |              |            |       |        |
|              |      |         |             |        |      |      |              |              |            |       |        |
|              | A1   | 08Mar14 |             | kuang  | D.Z  | DWN  | Jackson_lee  | Part No.     | C-09-0155- | Scale | 4 : 1  |
|              | A    | 06Mar13 | RELEASED    | lee    | D.Z  | CHKD | CIYONG_JIANG | Old Part No. |            | Sheet | 1 of 1 |
| ECN(DCN) NO. | REV. | DATE    | DESCRIPTION | CHANGE | APVD | APVD | DAVID_ZHONG  | UNIT         | mm         | SIZE  | A4     |

TOLERANCES UNLESS OTHERWISE SPECIFIED  
 X. ±0.30 X." ±2"  
 .X ±0.25 X.X" ±1"  
 .XX ±0.15  
 .XXX ±0.10

|             |                     |             |
|-------------|---------------------|-------------|
| YES         | G/F                 | 09-0155-01  |
| HalogenFree | MIN. GOLD THICKNESS | PART NUMBER |

JS HAOGUO(Zhongxiang) Limited Company

Customers Drawing TITEL: SLIMLINE SATA 7+6 REC CONNECTOR

|              |            |       |        |
|--------------|------------|-------|--------|
| Part No.     | C-09-0155- | Scale | 4 : 1  |
| Old Part No. |            | Sheet | 1 of 1 |
| UNIT         | mm         | SIZE  | A4     |

