

REV.	DESCRIPTION	DATE	DWN	APVD
C1		29FEB12	Lee	WZ
C2		07Jun12	Lee	WZ

NOTE:
 1. MATERIAL:
 HOUSING: LCP UL 94V-0, COLOR: BLACK .
 CONTACTS: PHOSPHOR BRONZE .
 SERIES PIECE:BRASS .

2. FINISH:
 CONTACTS: GOLD (SEE TABLE) PLATED ON CONTACT AREA,
 2.54um [100μ"] MIN. MATTE-TIN ON SOLDER TAIL, WITH ENTIRE CONTACT
 UNDERPLATED 1.27um [50μ"]MIN. NICKEL.
 SERIES PIECE: 2.54um [100μ"] MIN. MATTE-TIN PLATING ON SOLDER
 TAIL, 1.27um [50μ"] MIN. NICKEL UNDERPLATING OVERALL.

3.ELECTRICAL:
 CONTACT RESISTANCE: 45 mΩ MAX.
 DIELECTRIC WITHSTANDING VOLTAGE: 500V AC
 CURRENT RATING: 1.5A
 VOLAGE RATING: 12V AC

4.ENVIRONMENTAL:
 OPERATING TEMPERATURE: -25°C TO +85°C

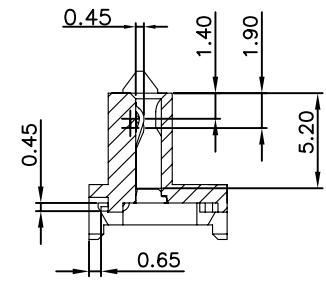
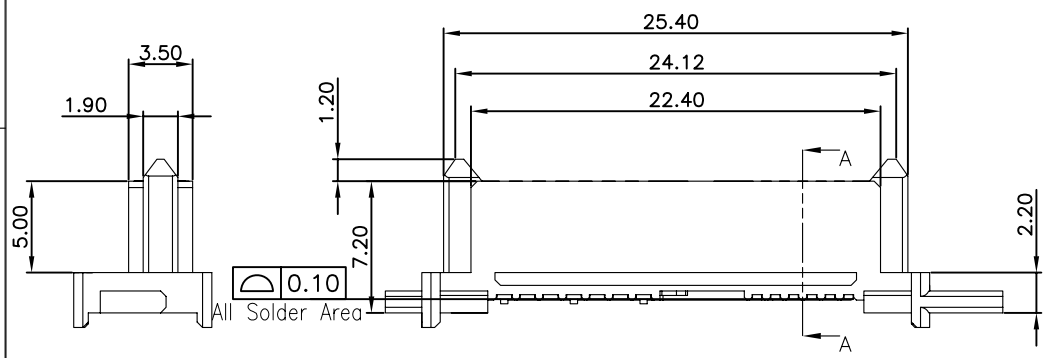
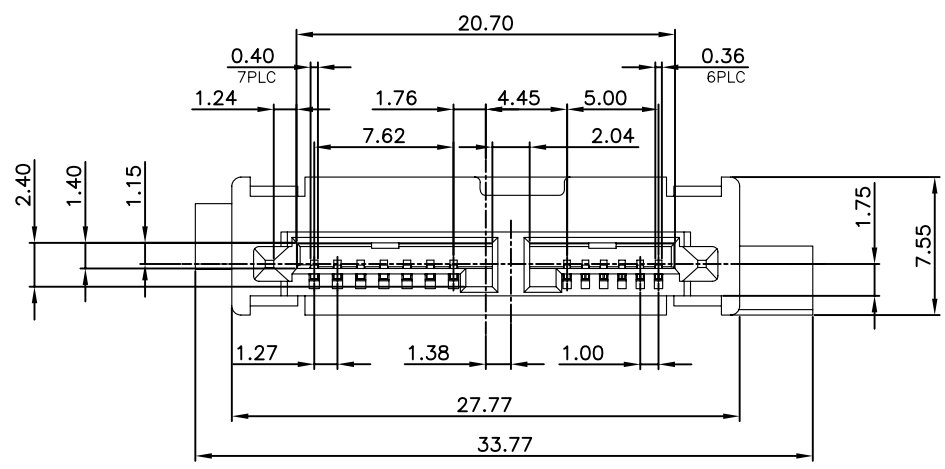

MATTING STATUS APPLICATION (REF.):
 1. HARD DISK STRAIGHT INSERT SATA RECEPTACLE UNDER BOARD
 2. HARD DISK OPPOSITE INSERT SATA RECEPTACLE ABOVE BOARD

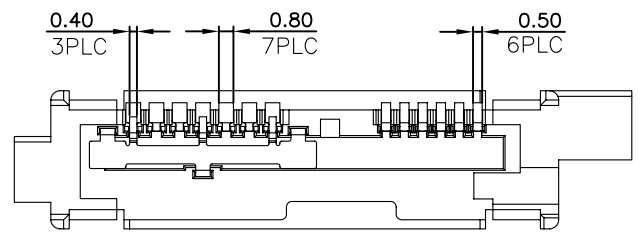
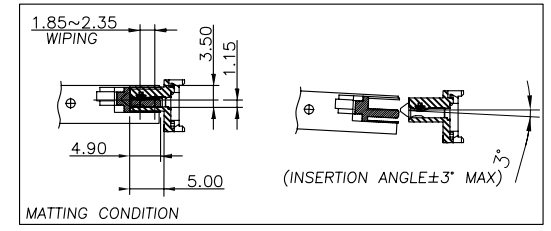

	30μ"	09-0066-05-H
	10μ"	09-0066-04-H
	G/F	09-0066-03-H
	10μ"	09-0066-02
	G/F	09-0066-01
	MIN. GOLD THICKNESS	PART NUMBER

TOLERANCES UNLESS OTHERWISE SPECIFIED: 0 PLC ± - 1 PLC ± 0.3 2 PLC ± 0.2 3 PLC ± 0.15 4 PLC ± - ANGLES ± 3°	DWN Ben_Chen 07June2010 CHK CIYONG_JIANG 07June2010 APVD Wei_ZHANG 07June2010 PRODUCT SPEC	Zhongxiang Electron Science CO.,LTD	
MATERIAL SEE NOTE	APPLICATION SPEC	NAME	
FINISH SEE NOTE	WEIGHT	SATA 7+6P REC. V/T Solderless Type	
PROJECTION	DIMENSIONS: MM	SIZE A3	DRAWING NO C-09-0066
		CUSTOMER DRAWING	RESTRICTED TO -
		SCALE -	SHEET 1 OF 1
			REV C2