

NOTE:

1. MATERIAL:
HOUSING: LCP UL 94V-0, COLOR: BLACK .
CONTACTS: PHOSPHOR BRONZE .
SERIES PIECE: BRASS .
2. FINISH:
CONTACTS: GOLD (SEE TABLE) PLATED ON CONTACT AREA,
2.54 μ m [100 μ "] MIN. MATTE-TIN ON SOLDER TAIL, WITH ENTIRE CONTACT UNDERPLATED 1.27 μ m [50 μ "] MIN. NICKEL.
SERIES PIECE: 2.54 μ m [100 μ "] MIN. MATTE-TIN PLATING ON SOLDER TAIL, 1.27 μ m [50 μ "] MIN. NICKEL UNDERPLATING OVERALL.
3. ELECTRICAL:
CONTACT RESISTANCE: 45 m Ω MAX.
DIELECTRIC WITHSTANDING VOLTAGE: 500V AC
CURRENT RATING: 1.5A
VOLTAGE RATING: 12V AC
4. ENVIRONMENTAL:
OPERATING TEMPERATURE: -25°C TO +85°C

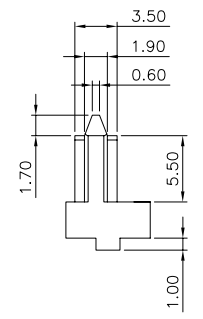

MATTING STATUS APPLICATION (REF.):
1. HARD DISK STRAIGHT INSERT SATA RECEPTACLE UNDER BOARD
2. HARD DISK OPPOSITE INSERT SATA RECEPTACLE ABOVE BOARD

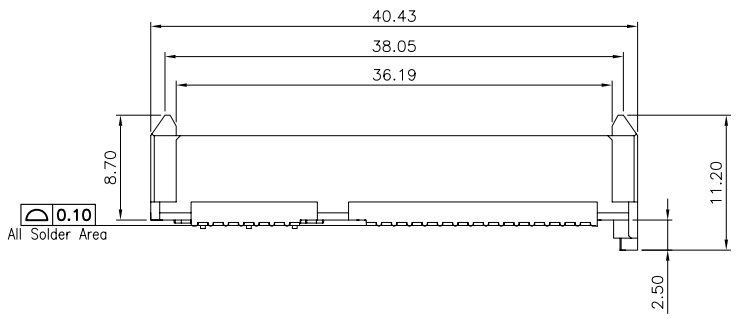
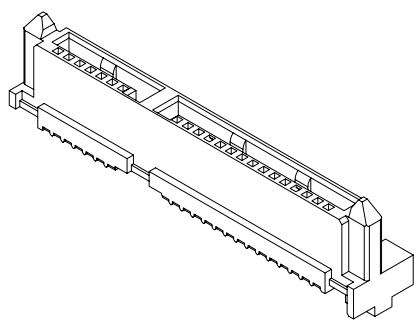
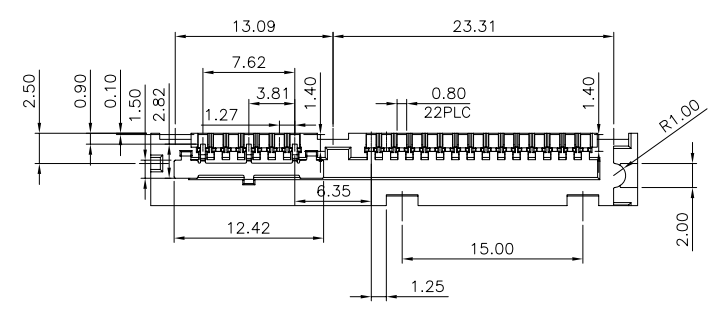
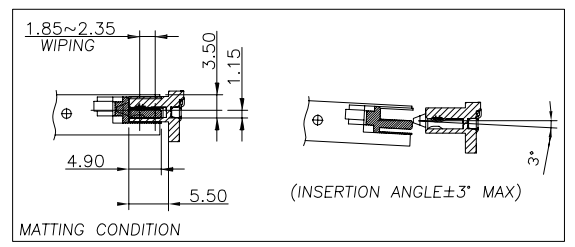

TABLE:

WITHOUT	WITHOUT	30 μ "	09-0065-05
WITH		10 μ "	09-0065-04-H
WITHOUT		GOLD FLASH	09-0065-03-H
		10 μ "	09-0065-02
WITHOUT	GOLD FLASH	09-0065-01	
LOGO	COVER	GOLD THICKNESS	PART NUMBER

ECN(DCN) NO.	REV.	DATE	DESCRIPTION	CHANGE	APVD	APVD	DAVID_ZHONG
	E1	26OCT13		KUANG	D.Z		
	E	24Sep13	RELEASED	KUANG	D.Z	DWN	JUANPING_KUANG
	D1	24Sep12	add P/N	john	D.Z	CHKD	CIYONG_JIANG

TOLERANCES UNLESS OTHERWISE SPECIFIED
X. ±0.30 X." ±2"
.X ±0.25 X.X" ±1"
.XX ±0.20
.XXX ±0.10

JS HAOGUO(Zhongxiang) Limited Company

Customers Drawing TITEL: SATA 7+15P Receptacle V/T Solderless Type

Part No. SEE TABLE Scale 4 : 1

Drawing No. C-09-0065 Sheet 1 of 1

UNIT mm SIZE A4 Third Angle Projection