

REV.	DESCRIPTION	DATE	DWN	APVD
A	RELEASED	28AUG09	A.X	J.Y

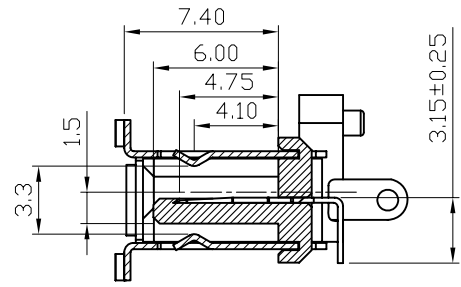

SECTION A-A

NOTE:
 PRODUCTS MUST CONFORM TO JS SPEC JS-GC03143-A1.
 1.MATERIAL:
 HOUSING: LCP; UL94V-0; COLOR:BLACK
 CONTACT: BRASS . T=0.25mm.
 BOARDLOCK :BRASS . T=0.30mm.
 2.FINISH:
 CONTACT: 0.381um [15μ"] MIN. GOLD PLATING ON CONTACT AREA
 2.54um [100μ"] MIN. TIN PLATING ON SOLDERTAILS
 1.27um [50μ"] MIN. NICKEL UNDERPLATING OVER ALL
 BOARDLOCKS: 1.27um [50μ"] MIN. NICKEL PLATED.
 3.ELECTRICAL:
 CONTACT RESISTANCE: 45 mΩ MAX.
 DIELECTRIC WITHSTANDING VOLTAGE: 500V AC
 CURRENT RATING: 1.5A
 VOLTAGE RATING: 12V AC
 4.ENVIRONMENTAL:
 OPERATING TEMPERATURE: -25°C TO +85°C

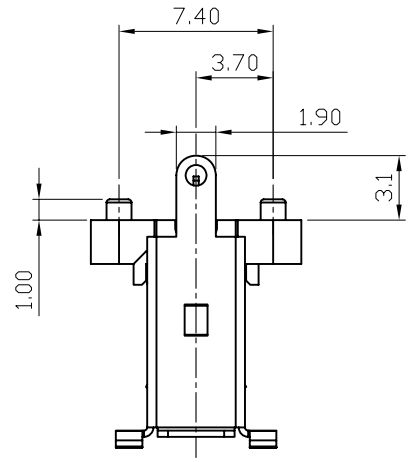
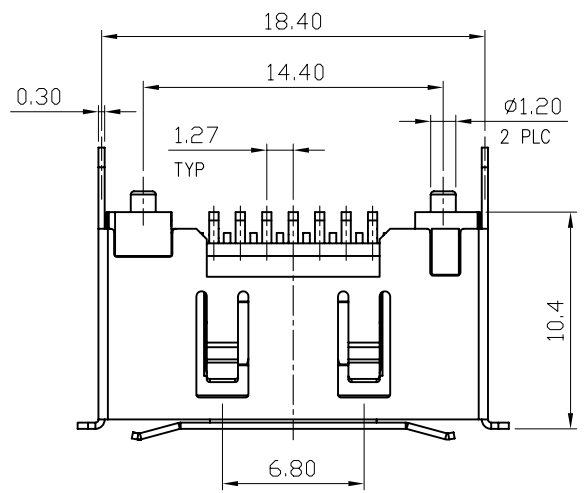
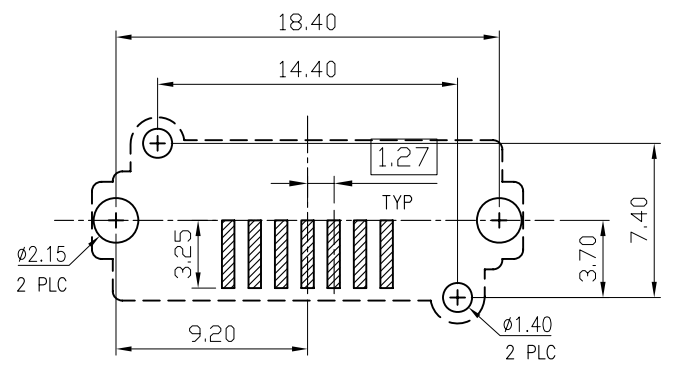
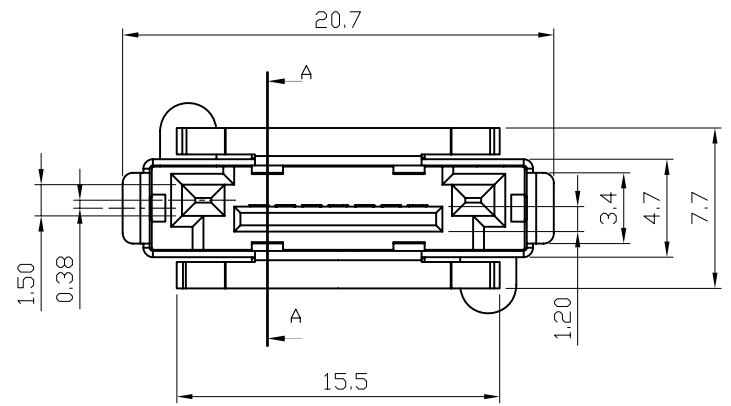

RECOMMEND PCB LAYOUT
 PCB TOLERANCE:±0.05

TOLERANCES UNLESS OTHERWISE SPECIFIED:	DWN	28AUG2009
0 PLC ± -	ANDY_XIAO	
1 PLC ± 0.3	CHK	28AUG2009
2 PLC ± 0.2	GAVIN_CHEN	
3 PLC ± 0.15	APVD	28AUG2009
4 PLC ± -	JACKY_YANG	
ANGLES ± 3°	PRODUCT SPEC	
MATERIAL	SEE NOTE	APPLICATION SPEC
FINISH	SEE NOTE	WEIGHT
PROJECTION		DIMENSIONS: MM

SI2713107FB000A7	0.381μm [15μ"]	09-0031-01
OLD PART NUMBER	MIN. GOLD THICKNESS	PART NUMBER

Zhongxiang Electron Science CO.,LTD

E-SATA 7P VERTICAL SMT PLUG

SIZE	DRAWING NO	RESTRICTED TO
A3	C-09-0031	-
CUSTOMER DRAWING	SCALE	SHEET 1 of 1
REV	A	