

REV.	DESCRIPTION	DATE	DWN	APVD
A	RELEASED	28AUG09	A.X	J.Y
A1	(A1)	28May2012	lee	W.Z

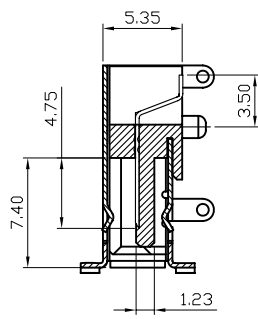
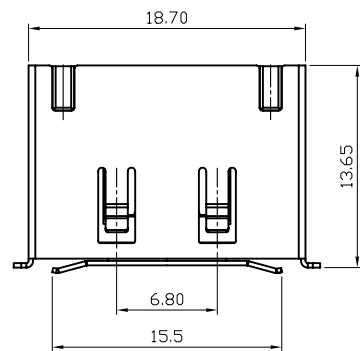

SECTION A-A  
SCALE 1:1

NOTE:  
PRODUCTS MUST CONFORM TO JS SPEC JS-GC03143-A1.

1.MATERIAL:  
HOUSING: LCP; UL94V-0; COLOR:BLACK  
CONTACT: BRASS . T=0.25mm.  
SHELL :BRASS . T=0.30mm.

2.FINISH:  
CONTACT: (SEE TABLE) GOLD PLATING ON CONTACT AREA  
2.54um [100μ"] MIN. TIN PLATING ON SOLDERTAILS  
1.27um [50μ"] MIN. NICKEL UNDERPLATING OVER ALL  
SHELL: 1.27um [50μ"] MIN. NICKEL PLATED.

3.ELECTRICAL:  
CONTACT RESISTANCE: 45 mΩ MAX.  
DIELECTRIC WITHSTANDING VOLTAGE: 500V AC  
CURRENT RATING: 1.5A  
VOLAGE RATING: 12V AC

4.ENVIRONMENTAL:  
OPERATING TEMPERATURE: -25°C TO +85°C

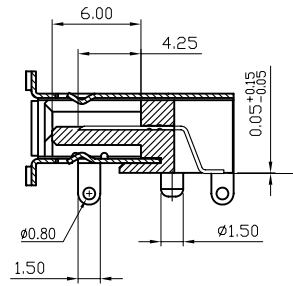
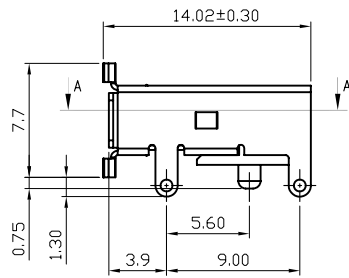
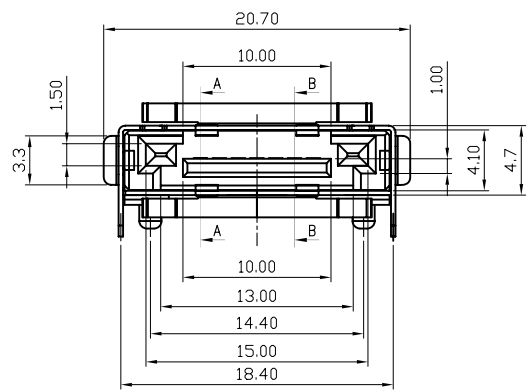

SECTION B-B  
SCALE 1:1

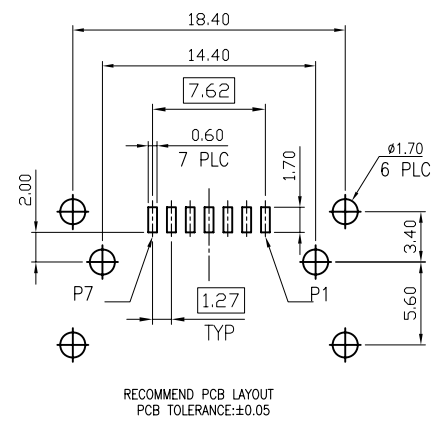
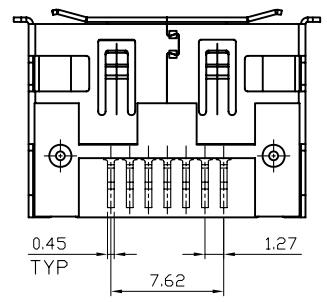

RECOMMEND PCB LAYOUT  
PCB TOLERANCE:±0.05

(A1)	YES	GOLD FLASH	09-0029-04-H
	NO	GOLD FLASH	09-0029-03
	NO	0.762μm [30μ"]	09-0029-02
	NO	0.381μm [15μ"]	09-0029-01
	Halogen free	MIN. GOLD THICKNESS	PART NUMBER

TOLERANCES UNLESS OTHERWISE SPECIFIED:		DWN ANDY_XIAO 28AUG2009	<b>Zhongxiang Electron Science CO.,LTD</b>	
0 PLC ± -	1 PLC ± 0.3	CHK GAVIN_CHEN 28AUG2009		
2 PLC ± 0.2	3 PLC ± 0.15	APVD JACKY_YANG 28AUG2009	NAME	
4 PLC ± -	ANGLES ± 3°	PRODUCT SPEC	E-SATA 7P RIGHT ANGLE SMT PLUG	
MATERIAL SEE NOTE	APPLICATION SPEC	SIZE A3	DRAWING NO C-09-0029	RESTRICTED TO
PROJECTION	WEIGHT	CUSTOMER DRAWING		
DIMENSIONS: MM		SCALE -	SHEET 1 of 1	REV A1