

VIEW C
SCALE 2:1

NOTE:
PRODUCTS MUST CONFORM TO JS SPEC JS-GC03143-A1.

- MATERIAL:
HOUSING: LCP UL 94V-0, COLOR: BLACK .
CONTACTS: PHOSPHOR BRONZE, T=0.25mm.
BOARDLOCKS: BRASS, T=0.40mm.
- FINISH:
CONTACTS: GOLD FALSH PLATED ON CONTACT AREA,
2.54um [100μ"] MIN. BRIGHT-TIN ON SOLDER TAIL,
WITH ENTIRE CONTACT UNDERPLATED 1.27um [50μ"]MIN. NICKEL.
BOARDLOCKS: 2.54um [100μ"] MIN. BRIGHT-TIN OVER 1.27um [50μ"] MIN.
NICKEL PLATED.
- ELECTRICAL:
CONTACT RESISTANCE: 45 mΩ MAX.
DIELECTRIC WITHSTANDING VOLTAGE: 500V AC
INSULATION RESISTANCE:1000MΩ/500V DC FOR 1MINUTE
CURRENT RATING: 1.5A
VOLAGE RATING: 12V AC
- ENVIRONMENTAL:
OPERATING TEMPERATURE: -25°C TO +85°C
- MECHANICAL:
MATING FORCE:4.59KG MAX.
UNMATING FORCE:1.02KG MIN.
DURABILITY: 500 CYCLES.
CONTACT RETENTION FORCE: 0.1KG/PIN

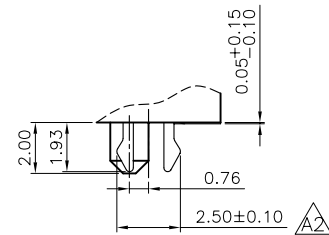
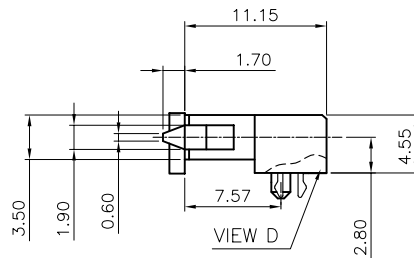
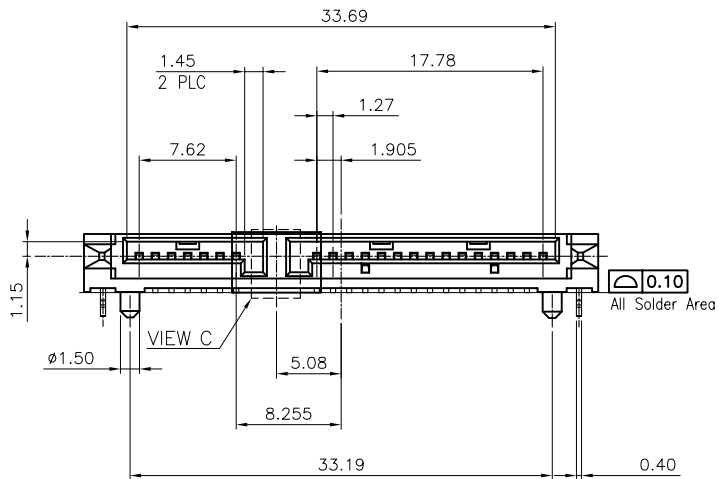

VIEW D
SCALE 2:1

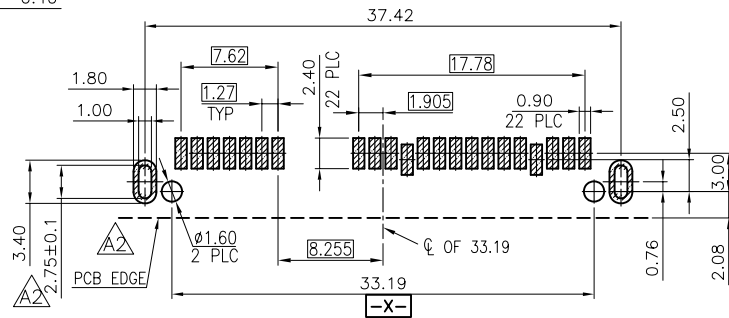
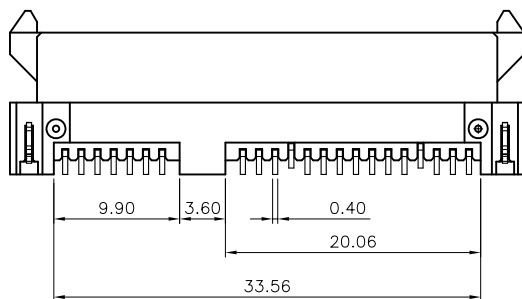

RECOMMEND P.C.B LAYOUT
PCB TOLERANCE:±0.05

NO	YES	30μ"		09-0027-05
YES	YES	30μ"		09-0027-04
YES	YES	G/F		09-0027-03
NO	NO	15μ"	SB3718822FB0H0S2	09-0027-02
NO	NO	G/F	SB3718822FB0J0S2	09-0027-01
CAP	HalogenFree	GOLD THICKNES	OLD PART NUMBER	NEW PART NUMBER

TOLERANCES UNLESS OTHERWISE SPECIFIED			
X.	±0.30	X.'	±2'
.X	±0.25	X.X'	±1'
.XX	±0.15		
.XXX	±0.10		

JS HAOGUO(Zhongxiang) Limited Company

Customers Drawing
TITEL: SERIAL ATA CONNECTOR, 22 POSITION, RIGHT ANGLE, SMT, H=4.55mm.

ECN(DCN) NO.	REV.	DATE	DESCRIPTION	CHANGE	APVD	APVD	DAVID_ZHONG	UNIT	mm	SIZE	A4	Third Angle Projection
	A2	20MAR14		KJP	D.Z			Part No.		Scale	1 : 1	
	A1	03July13		Lee	D.Z	DWN	ANDY_XIAO	Drawing No.	C-09-0027-	Sheet	1 of 1	
	A	24JUNE13	RELEASED	Lee	D.Z	CHKD	CIYONG_JIANG					