

NOTE:
 PRODUCTS MUST CONFORM TO JS SPEC JS-GC03143-A1.

1. MATERIAL:
 HOUSING: (SEE TABLE) UL 94V-0, COLOR: BLACK .
 CONTACTS: PHOSPHOR BRONZE, T=0.25mm.
 BOARDLOCKS: BRASS, T=0.30mm.

2. FINISH:
 CONTACTS: GOLD (SEE TABLE) PLATED ON CONTACT AREA,
 2.54um [100μ"] MIN. TIN ON SOLDER TAIL, WITH ENTIRE CONTACT
 UNDERPLATED 1.27um [50μ"] MIN. NICKEL.
 BOARDLOCKS: 2.54um [100μ"] MIN. TIN OVER 1.27um [50μ"] MIN. NICKEL ON ENTIRE BOARDLOCK.

3. ELECTRICAL:
 CONTACT RESISTANCE: 45 mΩ MAX.
 DIELECTRIC WITHSTANDING VOLTAGE: 500V AC
 CURRENT RATING: 1.5A
 VOLTAGE RATING: 12V AC

4. ENVIRONMENTAL:
 OPERATING TEMPERATURE: -25°C TO +85°C

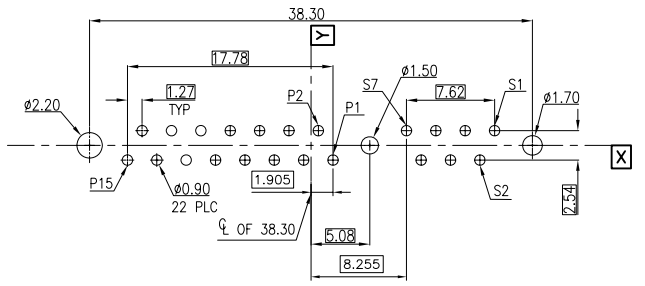
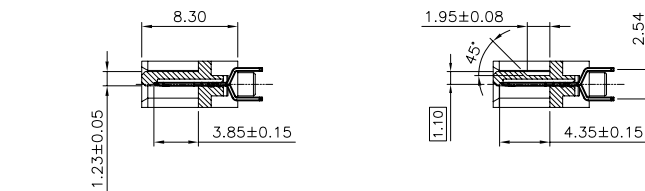
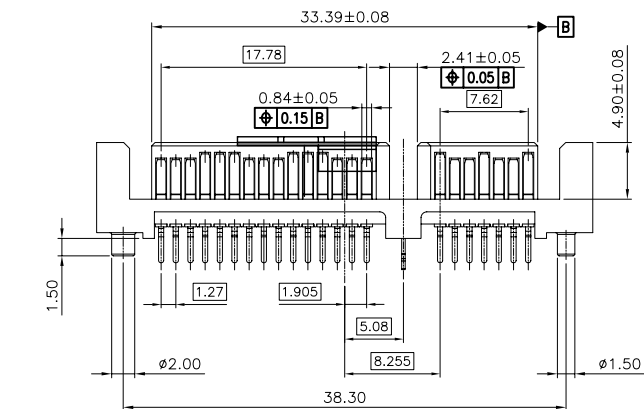

RECOMMEND PCB LAYOUT
 PCB TOLERANCE: ±0.05

△	YES	GOLD FLASH	LCP	_____	09-0015-05
	NO	15μ"	PA6T	SF0209722FB000S2	09-0015-04
△	YES	GOLD FLASH	LCP	SF0709722FB000S2	09-0015-03
	NO	GOLD FLASH	PA6T	SF0709722FB0C0S2	09-0015-02
	NO	GOLD FLASH	PA6T	SF0209722FB0C0S2	09-0015-01
	Halogen Free	GOLD THICKNES	HOUSING MATERIAL	OLD PART NUMBER	PART NUMBER

JS HAOGUO(Zhongxiang) Limited Company

	A2	17JUI14	△	KJP	DZ														
	A1	28APR14	△	KJP	DZ	DWN	JUNAPING_KUANG												
	A	28AUG09	RELEASED	AX	JY	CHKD	CIYONG_JIANG												
ECN(DCN) NO.	REV.	DATE	DESCRIPTION	CHANGE	APVD	APVD	DAVID_ZHONG	UNIT	mm	SIZE	A4	Third Angle Projection							

TOLERANCES UNLESS OTHERWISE SPECIFIED
 X. ±0.30 X.* ±2*
 .X ±0.25 X.X* ±1*
 .XX ±0.20
 .XXX ±0.10

Customers Drawing
 TITEL: SERIAL ATA CONNECTOR, 22 POSITION, PLUG, VERTICAL, DIP.
 Part No. _____
 Drawing No. C-09-0015
 Scale 1:1
 Sheet 1 of 1