

SECTION A-A

NOTE:
 PRODUCTS MUST CONFORM TO JS SPEC JS-GC03143-A1.
 1.MATERIAL:
 HOUSING: LCP+30% G.F, UL94V-0; COLOR:BLACK;
 CONTACT: BRASS. T=0.25mm
 BOARDLOCK :BRASS. T=0.30mm
 2.FINISH:
 CONTACT: (SEE TABLE) GOLD PLATING ON CONTACT AREA
 2.54um [100μ"] MIN. BRIGHT TIN PLATING ON SOLDERTAILS
 1.27um [50μ"] MIN. NICKEL UNDERPLATING OVER ALL
 BOARDLOCKS: 2.54um [100μ"] MIN. BRIGHT TIN OVER 1.27um [50μ"] MIN. NICKEL PLATED.
 3.ELECTRICAL:
 CONTACT RESISTANCE: 45 mΩ MAX.
 DIELECTRIC WITHSTANDING VOLTAGE: 500V AC
 CURRENT RATING: 1.5A
 VOLAGE RATING: 12V AC
 4.ENVIRONMENTAL:
 OPERATING TEMPERATURE: -25°C TO +85°C

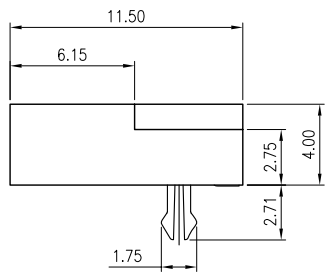

SECTION B-B

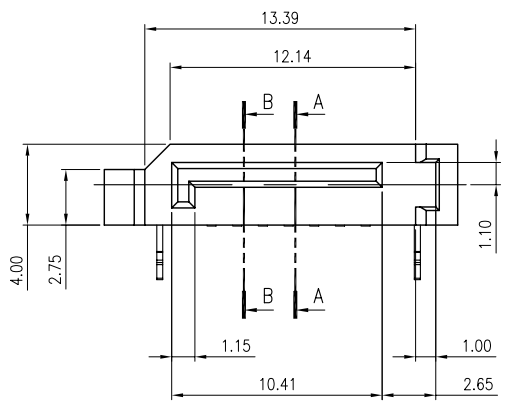
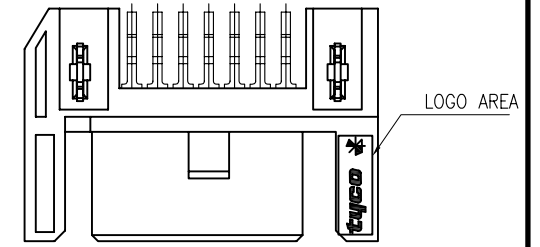
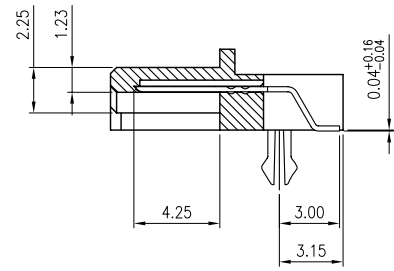

WITH TYCO LOGO TYPE

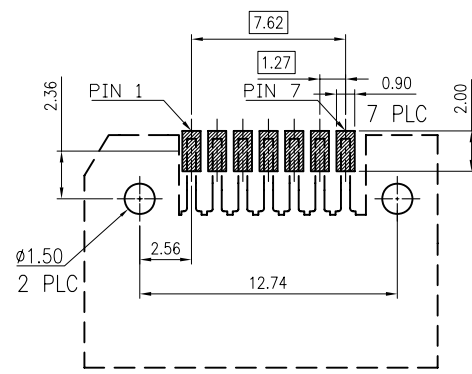
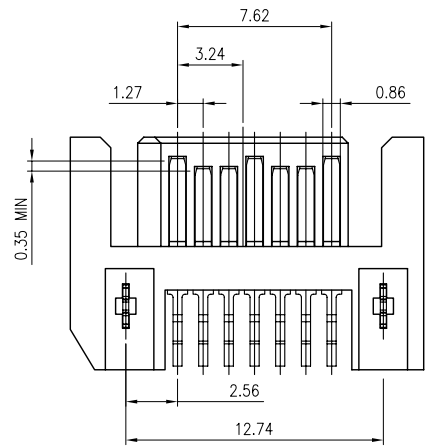

RECOMMENDED PCB LAYOUT
 TOLERANCE: ±0.05

3	YES	WITH TYCO LOGO	50μ"		09-0013-04
	NO	WITH TYCO LOGO	15μ"	SCB711607FBOCBM0	09-0013-03
2	NO	NO TYCO LOGO	G/F	SCB711607FBOCBM0	09-0013-02
			15μ"	SCB711607FBO0BM0	09-0013-01
	HalogenFree	TYCO LOGO	MIN.GOLD THICKNES	OLD PART NUMBER	NEW PART NUMBER

TOLERANCES UNLESS OTHERWISE SPECIFIED

X.	±0.30	X.*	±2*
.X	±0.25	X.X*	±1*
.XX	±0.20		
.XXX	±0.10		

JS HAOGUO(Zhongxiang) Limited Company

Customers Drawing	TITEL: SATA 7P RIGHT ANGLE A TYPE SMT PLUG			
Part NO.				Scale 1 : 1
Drawing No.	C-09-0013-			Sheet 1 of 1
UNIT	mm	SIZE	A4	Third Angle Projection

ECN(DCN) NO.	REV.	DATE	DESCRIPTION	CHANGE	APVD	APVD	DAVID_ZHONG
	A3	19July13		lee	D.Z	DWN	ANDY_XIAO
	A2	05JUN10		A.X	J.Y	CHKD	CIYONG_JIANG