

- NOTES:
- MATERIAL:
 - HOUSING: (SEE TABLE) UL94 V-0, COLOR:(SEE TABLE).
 - CONTACT 1: PHOSPHOR BRONZE C5191R-1/2H.T=0.30mm.
 - CONTACT 2: PHOSPHOR BRONZE C5191R-1/2H.T=0.30mm.
 - CONTACT 3: BRASS. C2680R-H. T=0.25mm.
 - CONTACT 4: PHOSPHOR BRONZE C5191R-1/2H.T=0.30mm.
 - FINISH:
 - CONTACT: 0.0203 μ m [0.8 μ "] MIN GOLD PLATED ON CONTACT AREA, 2.54 μ m [100 μ "] MIN.BRINGHT-TIN ON SOLDER TAILS, WITH ENTIRE CONTACT UNDER PLATED 1.27 μ m [50 μ "] MIN NICKEL.
 - ELECTRICAL:
 - CONTACT RESISTANCE: 30 m Ω Max.
 - INSULATOR RESISTANCE: 1000M Ω Min.
 - CURRENT RATING: 9 A MAX.
 - DIELECTRIC WITHSTANDING VOLTAGE:250V AC/DC MAX
 - ENVIRONMENTAL:
 - OPERATING TEMPERATURE: -25° TO +85°C

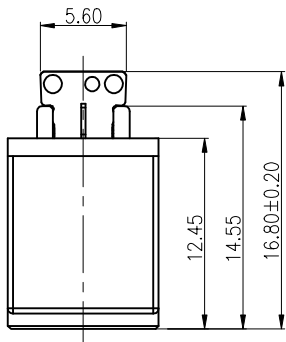

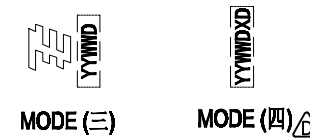
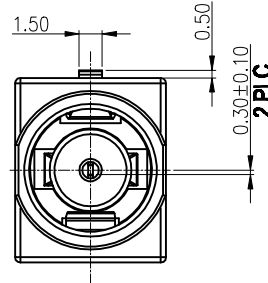
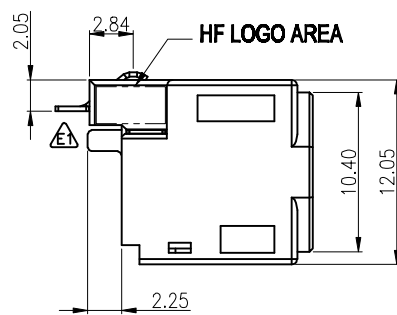
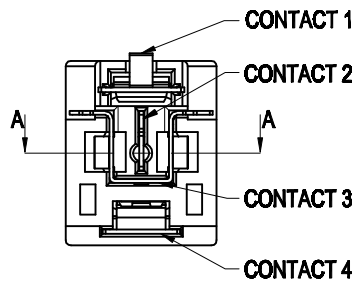

 "HF" Halogen-free logo

YELLOW (108C)	COMMON CARTON	HTN HALOGEN FREE	NONE	△ 06-0001-04-H
YELLOW (109C)		PA9T	SEE MODE (-)	△ 06-0001-03-H
YELLOW (108C)	COMMON CARTON	HTN HALOGEN FREE	NONE	06-0001-04
		PA9T	SEE MODE (-)	06-0001-03
			SEE MODE (≡)	06-0001-02
			NONE	06-0001-01
COLOR	PACKING	MATERIAL	LOGO& DATE CODE	PART NO.

F	△	19AUG13	XU	DZ
E3	△	20DEC2011	PH	WZ
E1	△	ECN11062801	ZH	DZ
REV.		DESCRIPTION	DATE	DWN APVD

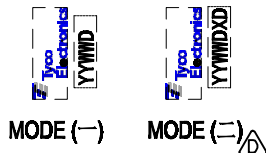
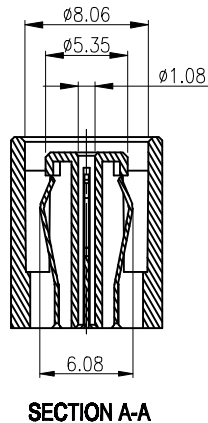
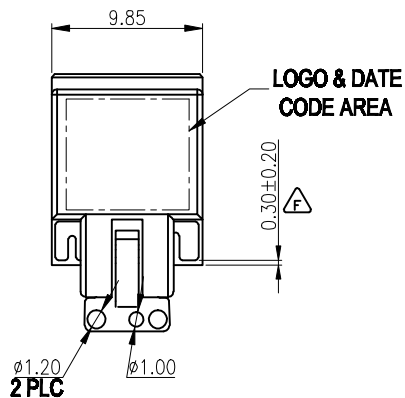
TOLERANCES UNLESS OTHERWISE SPECIFIED:		DWN PING_HE 20DEC2011	Zhongxiang Electron Science CO.,LTD	
0 PLC	± -	CHK CIYONG_JIANG 20DEC2011		
1 PLC	± 0.3	APVD WEI_ZHANG 20DEC2011	NAME	
2 PLC	± 0.2	PRODUCT SPEC		
3 PLC	± 0.15	JS-GC03118-A1		
4 PLC	± -	APPLICATION SPEC		
ANGLES	± 5°	DC JACK-01-01		
MATERIAL SEE NOTE		DC JACK		
FINISH SEE NOTE		SIZE	DRAWING NO	RESTRICTED TO
PROJECTION		A3	C-06-0001	-
DIMENSIONS: MM		CUSTOMER DRAWING	SCALE -	SHEET 1 OF 2
				REV F



- NOTES:
- MATERIAL:
 - HOUSING: (SEE TABLE) UL94 V-0, COLOR:(SEE TABLE).
 - CONTACT 1: PHOSPHOR BRONZE C5191R-1/2H.T=0.30mm.
 - CONTACT 2: PHOSPHOR BRONZE C5191R-1/2H.T=0.30mm.
 - CONTACT 3: BRASS. C2680R-H. T=0.25mm.
 - CONTACT 4: PHOSPHOR BRONZE C5191R-1/2H.T=0.30mm.
 - FINISH:
 - CONTACT: 0.0203μm [0.8μ"] MIN GOLD PLATED ON CONTACT AREA, 2.54μm [100μ"] MIN.BRIGHT-TIN ON SOLDER TAILS, WITH ENTIRE CONTACT UNDER PLATED 1.27μm [50μ"] MIN NICKEL.
 - ELECTRICAL:
 - CONTACT RESISTANCE: 30 mΩ Max.
 - INSULATOR RESISTANCE: 1000MΩ Min.
 - CURRENT RATING: 9 A MAX.
 - DIELECTRIC WITHSTANDING VOLTAGE:250V AC/DC MAX
 - ENVIRONMENTAL:
 - OPERATING TEMPERATURE: -25° TO +85°C

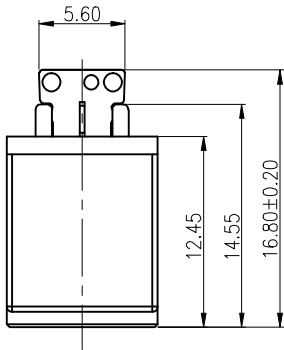
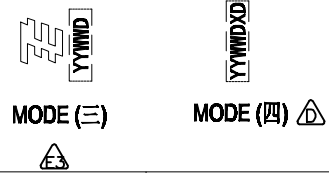
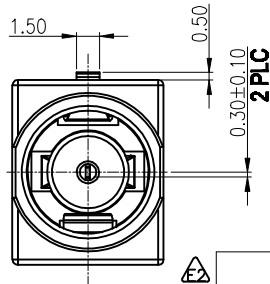
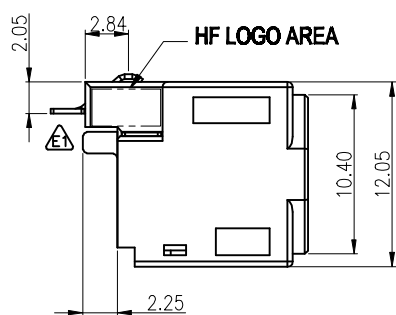
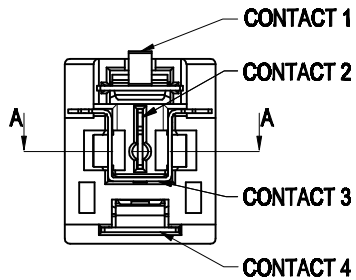

HF Halogen-free logo

YELLOW(107C)	COMMON CARTON	PA9T(HALOGEN FREE)	SEE MODE (四)	06-0001-13-H
		PBT(HALOGEN FREE)	SEE MODE (四)	06-0001-12-H
		PA10T(HALOGEN FREE)	SEE MODE (四)	06-0001-11-H
	TYCO CARTON	HTN	NONE	06-0001-08-H
		HALOGEN FREE	SEE MODE (二)	06-0001-07-H
	COMMON CARTON	PBT(HALOGEN FREE)	SEE MODE (四)	06-0001-12
		PA10T(HALOGEN FREE)	SEE MODE (四)	06-0001-11
		PA9T	SEE MODE (-)	06-0001-09
	TYCO CARTON	HTN	NONE	06-0001-08
		HALOGEN FREE	SEE MODE (二)	06-0001-07
PA9T		SEE MODE (二)	06-0001-06	
		SEE MODE (四)	06-0001-05	
COLOR	PACKING	MATERIAL	LOGO& DATE CODE	PART NO.

F	△	19AUG13	XU	DZ
E3	△	20DEC2011	PH	WZ
E1	△	ECN11062801	ZH	DZ
REV.		DESCRIPTION	DATE	DWN APVD

TOLERANCES UNLESS OTHERWISE SPECIFIED:		DWN PING_HE 20DEC2011		Zhongxiang Electron Science CO.,LTD	
0 PLC ± -		CHK CIYONG_JIANG 20DEC2011			
1 PLC ± 0.3		APVD WEI_ZHANG 20DEC2011		NAME	
2 PLC ± 0.2		PRODUCT SPEC		DC JACK	
3 PLC ± 0.15		MATERIAL JS-GC03118-A1		SIZE	
4 PLC ± -		APPLICATION SPEC		DRAWING NO	
ANGLES ± 5°		FINISH SEE NOTE		C-06-0001	
PROJECTION		WEIGHT		RESTRICTED TO	
DIMENSIONS: MM		CUSTOMER DRAWING		SCALE	
		SHEET 2 OF 2		REV F	