

NOTE:
 MATERIAL
 INSULATOR : NYLON 9T (UL94V-0)
 CONTACT : C2680
 CONTACT PLATED : GOLD FLASH OVER NICKEL OR TIN
 SPECIFICATION
 CURRENT RATING : 7A
 INSTANT CURRENT : 10A Ω
 CONTACT RESISTANCE : 30M Ω
 INSULATION RESISTANCE : 100M
 DIELECTRIC VOLTAGE : 500V
 OPERATING TEMPERATURE : -40° C~105° C

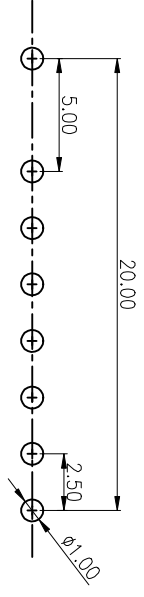
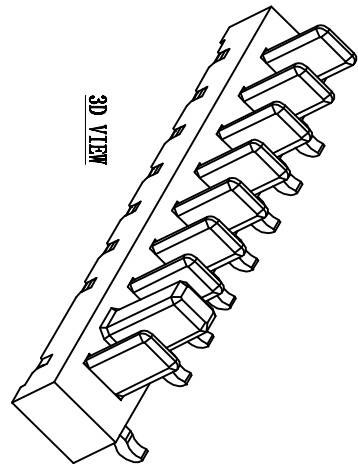

Recommended P.C.B. Layout
Layout Tolerance = ±0.05 mm

TOLERANCES UNLESS OTHERWISE SPECIFIED		JS HAOGUO(Zhongxiang) Limited Company	
X	±0.30	X	±2°
X	±0.25	X.X	±1°
.XX	±0.15	.XXX	±0.10
DWN	FUYONG_XU	Part NO.	02-0011-01
CHKD	QIYONG_JIANG	Drawing No.	C-02-0011
WEL_ZHANG		UNIT	mm
APVD		SIZE	A4
APVD		Scale	1:1
APVD		Sheet	1 of 1
APVD		Third Angle	Production

ECN(DCN) NO.	REV.	DATE	DESCRIPTION	CHANGE	APVD	APVD	WEL_ZHANG	UNIT	mm	SIZE	A4	Third Angle	Production
	A	13/05/20	NEW RELEASE	XU	DZ								